

Test Jack Panel

TJ-327-02D

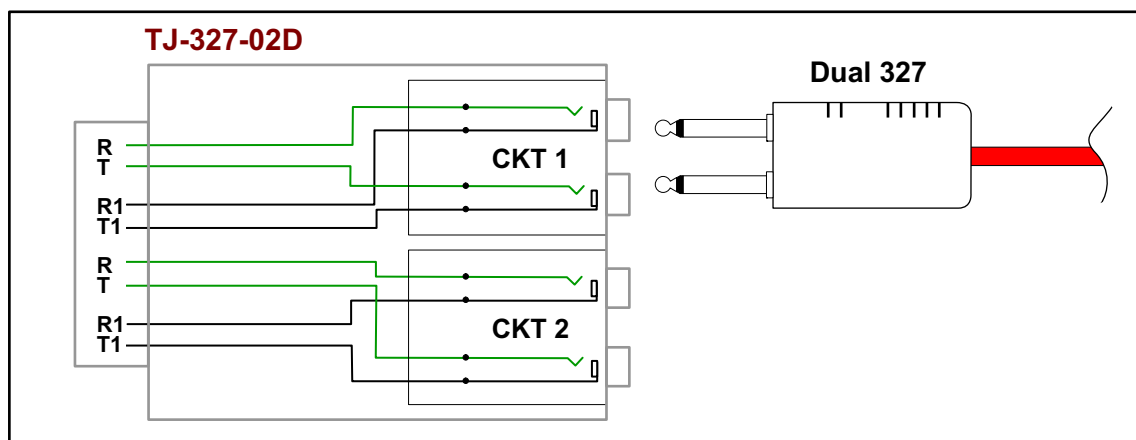

TJ-327-02D Test Jack Panel w/ (2) 327C Jacks

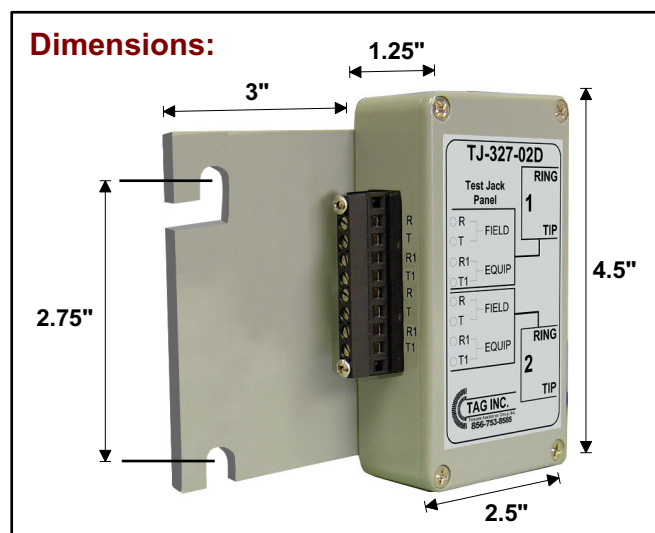

Application:

The TJ-327-02D Jack Panel provides access to (2) two independent Tip/Ring circuits using standard frame cords (Dual 327 to Protector). It conveniently mounts along the vertical side of the MDF. Connections are made to a terminal block at the rear of the unit.

Ordering Information:

TJ-327-02D

Test Jack Panel w/ (2) 327C Jacks

AT&T PID #

ATT.100035138

150 Cooper Rd. (F-15)
W. Berlin, NJ 08091

www.tagcords.com

Telephone: (856) 753-8585
Fax : (856) 768-7645

Telecom Assistance Group